

1/4 Scale P-39 Build.

13

Paul Fleming and Jim Lake
4/20/2022

Here is a link to visit all previous issues of this build. http://kitsaparcs.org/construction_fleming_quarter-scale_p-39.html

It's been about two weeks since the last update. Things have not gone exactly as planned. We started the testing we did get to full power for a short time when a failure occurred. Something came loose in the gearbox. The propeller shaft could turn freely.

Jim took the propulsion system home and opened the gearbox. That had happened was the drive gear had come loose from the shaft at full power. It turns out the set screw that secures the gear to the shaft was not tight. Only the shaft being pressed into the gear produced the friction that allowed the prop to be driven. When we got to full power it could no longer hold. There was no damage, the gear was reset and the system was ready to retest.

A couple of days later we tried again, this time something else went wrong. At about 60% power we got a radical change in sound. I shut it down immediately. We couldn't determine what was wrong at the time. Jim again took the system home for a tear down analysis. The driveshaft the coupler on the motor end had become loose allowing the shaft to freewheel. The fix here is to safety wire the nut to the coupler. We are going to get this testing thing started one of these days.

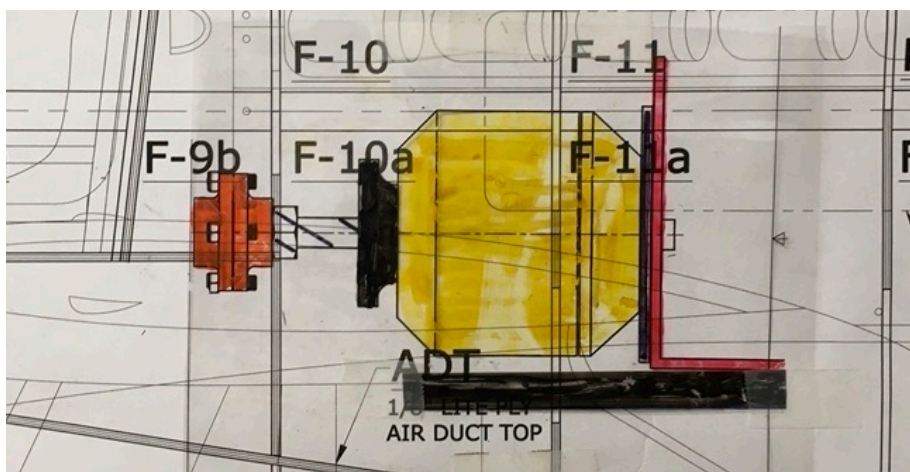

Last entry 4/20/2022