

# 1/4 Scale P-39 Build.

8

Paul Fleming and Jim Lake  
2/21/2022

*Here is a link to visit all previous issues of this build. [http://kitsaparcs.org/construction\\_fleming\\_quarter-scale\\_p-39.html](http://kitsaparcs.org/construction_fleming_quarter-scale_p-39.html)*

---

Jim has spent a great deal of time to make sure our gear is as true to scale as possible. The drag link and the fore link are the two most problematic parts. The location of these parts is critical to the way the gear folds and where the links come to rest when the gear is up. In Update #5 Mike Eversman provided us with dimensions taken from the actual aircraft.



The way the two links fold as the gear comes up scale parts must move through the area occupied by the Torque Plate. Precise clearance holes will be machined to prevent contact. As in the real aircraft, the links must not interfere with the drive shaft. We solved the problem by designing the fore link to fit around the outside of the driveshaft.



The permanent Torque plate has been machined. Before we install it we need to mount the Gearbox with Propeller Shaft and Nose bearing. With those components in place we can make a precise Propeller Shaft alignment. This is one of those places where the margin of error is almost nonexistent.

Our immediate problem is how to make the bearing mount. The mount will be made from sheet steel which would be quite difficult to mount on the mill. Using Fusion 360 you can produce a 3D drawing of your part and the program will convert it into a 2D flat file usable by cutting machines. Jim is looking around for a laser or a water cutter company to cut this part. If we can't find one close by Plan B will be activated.

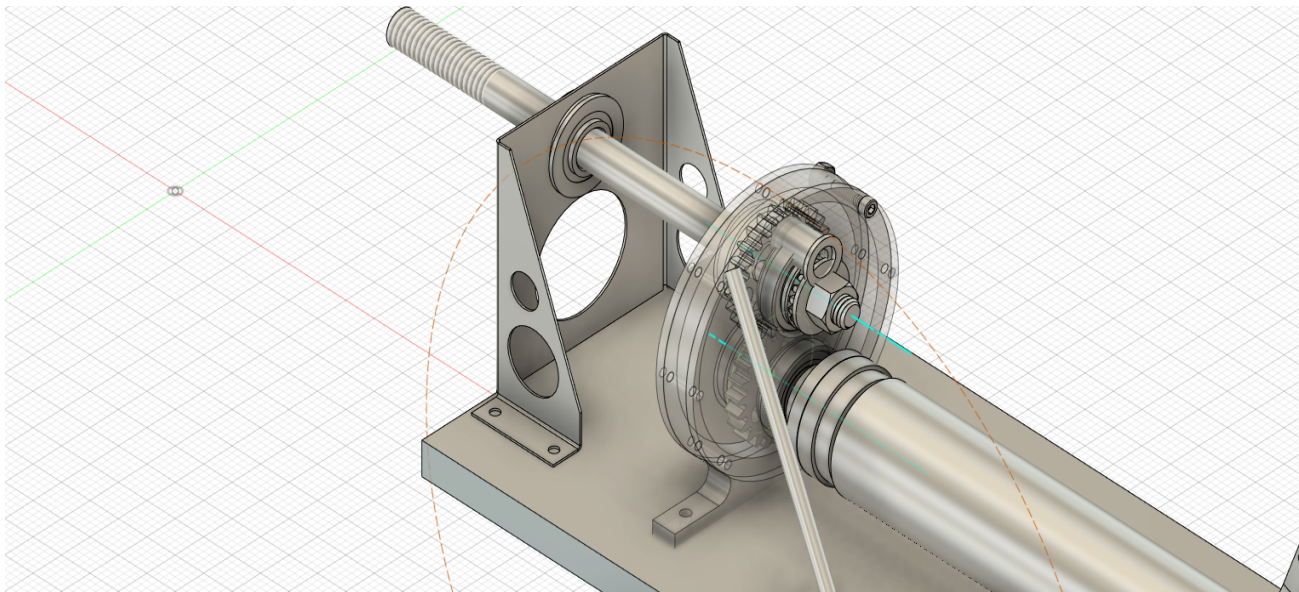
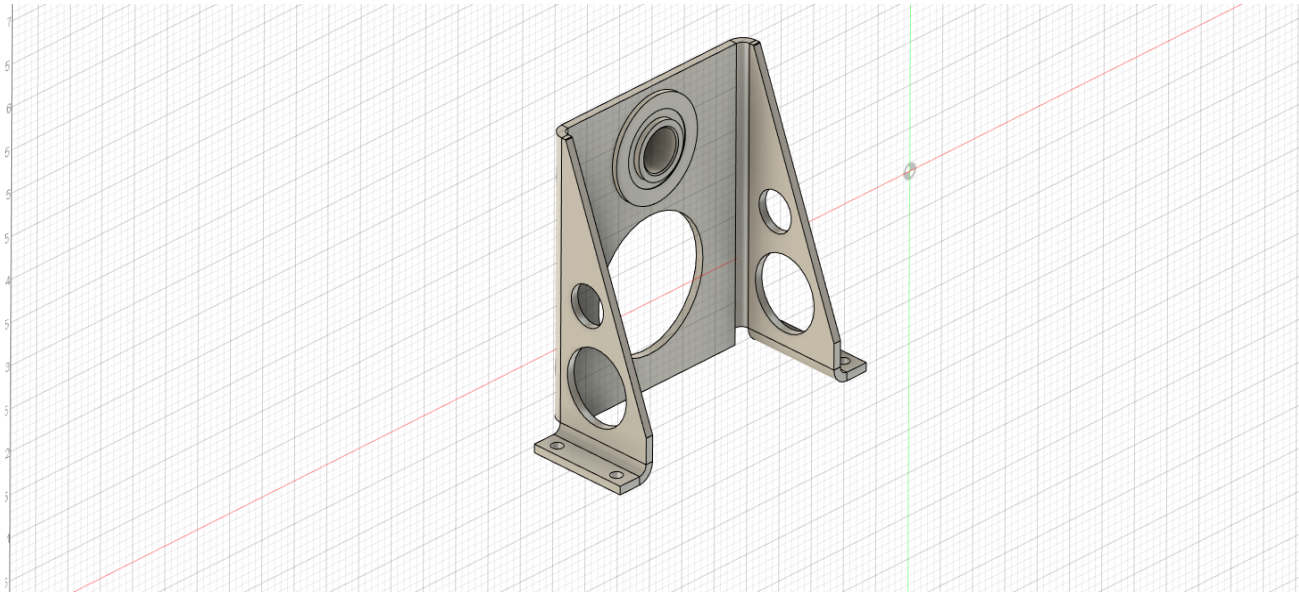

Looking ahead we've noticed none of the current aircraft stands will not be suitable for transporting, field assembly or landing gear operation. Typically on my 1/5 and 1/6 scale models installing the wings with the fuselage upside down and testing the gear is easy. Those models are a manageable size. Not here, since the wings will be installed with the fuselage upright we need at least 10 1/2" between the table and the bottom of the wings to operate the landing gear. The stand also needs to secure the plane in the trailer during transportation. Anybody with experience with quarter scale fighter planes I would like to know how you handle these things. Mostly what I have seen is guys kneeling on the ground getting up and down a lot. Laying on their back looking under the wing. There just seems there must be a better way. Any ideas would be welcome.

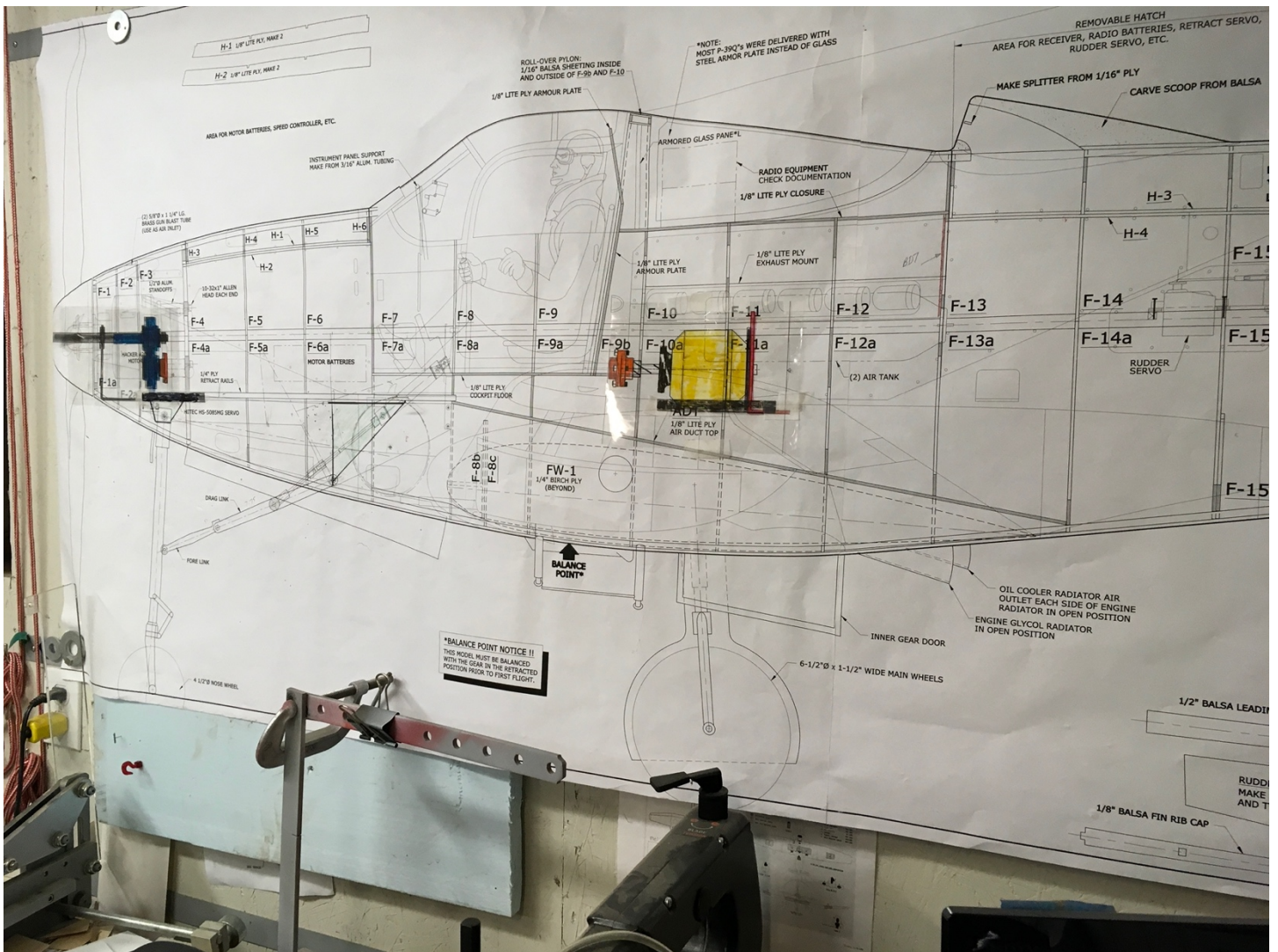

Last entry: 2/25/2022